

2022 NAAMLPL Hard Rock Abandoned Mine Lands Reclamation Awards

NOMINATION

Cookes Peak Mine Safeguard Project

Deming, New Mexico

Award Category:
Physical Safety Hazards

Submitted by:

New Mexico Abandoned Mine Land Program
Energy, Minerals and Natural Resources Dept.
1220 South St. Francis Drive
Santa Fe, New Mexico 87505

Mike Tompson
Program Manager
(505) 690-8063
Mike.Tompson@state.nm.us

And

U.S. Bureau of Land Management
Las Cruces District Office
1800 Marquess Street
Las Cruces, New Mexico 88005-3371

Chris Teske
Abandoned Mine Land Coordinator
(575) 525-4323
cteske@blm.gov

Project Summary:

Construction Start Date: October 22, 2014
Construction Completion Date: March 11, 2021
Construction Cost: \$1,457,673

Date Submitted:
June 17, 2022

Responsible Organizations

New Mexico Abandoned Mine Land Program

Mining & Minerals Division
1220 South St. Francis Drive
Santa Fe, NM 87505

U.S. Bureau of Land Management

Las Cruces District Office
1800 Marquess Street
Las Cruces, NM 88005-3371

Current and Former AML Program Staff:

Randall Armijo, Laurence D'Alessandro, James Hollen,
John Kretzmann, Steve Lakatos, Yeny Maestas, Meghan
McDonald, Lloyd Moiola, Amanda Muller, Leeland
Murray, Steve Needles, Jacob Pederson, Erin Taylor,
Mike Tompson, Angela Trujillo, Joe Vinson, Rick Wessel

Current and Former BLM Staff:

Francis "Dave" Brown, Jim Swartz, Chris
Teske

Supporting Individuals and Organizations

Bat Habitat Surveys

Dr. J. Scott Altenbach
Department of Biology
University of New Mexico
Albuquerque, NM 87131

and

Bat Conservation International
500 N Capital of TX Hwy. Bldg. 1
Austin, TX 78746

Archaeological Services

Museum of New Mexico
Office of Archaeological Studies

Endangered Plant Surveys

Daniela Roth
New Mexico Forestry Division
1220 South St. Francis Drive
Santa Fe, NM 87505

Environment Assessment

Environmental Planning Group, LLC.
4141 North 32nd Street, Suite 102
Phoenix, Arizona 85018

Engineering Design

-New Mexico Abandoned Mine Land Program
-Bureau of Land Management
-Hurricane Industries

Construction Contractors

Runyan Construction
P.O. Box 2827
Silver City, NM 88062

PERIKIN Enterprises, LLC
1314 Madeira Drive SE
Albuquerque, NM 87108

MineGates Environmental, Inc.
1240 West Cougar Lane
Prescott, AZ 86303

Hurricane Industries LLC
64290 Airway Rd.
Joseph, OR 97846

Bureau of Land Management

Key Cooperating Landowners

Public: U.S. Bureau of Land Management and New Mexico State Land Office

Private: Jim Wood and Leedrue Hyatt

Funding Partners

U.S. Bureau of Land Management
Las Cruces District Office
1800 Marquess Street
Las Cruces, NM 88005-3371

U.S. Office of Surface Mining Reclamation and Enforcement
Interior Regions 5, 7-11
One Denver Federal Center, Building 41
Lakewood, CO 80225-0065



Cookes Peak

The Cookes Peak Mine Safeguard Project was a collaboration between the New Mexico Abandoned Mine Land Program (NMAMLP) and the U.S. Bureau of Land Management – Las Cruces District Office (BLM). The project entailed seven phases of construction that took place between 2014 and 2021, safeguarding more than 291 hazardous mine openings. These features were abandoned long ago and included adits, shafts, stopes, highwalls and other dangerous conditions left over by legacy mining.

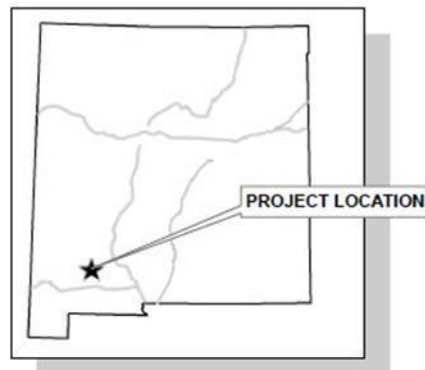

At an elevation of 8,408 ft, Cookes Peak is a prominent feature in southern New Mexico. The mountain, located 15 miles north of Deming, NM, can be seen from miles around. The Cookes Peak Mining District is located just to the north of the peak and the Old Hadley District just to the southeast. Silver and lead

were discovered in the Cookes Range around 1876; large-scale mines were opened five years later. Most lead/zinc/silver production had ended by 1929. However, fluorspar and base-metal production persisted until 1965. The output of lead, zinc, gold, silver, and copper ore fetched a total of \$4.2 million between 1876 and 1952. The spring at the south end of the mountains was a watering stop for the Overland Mail Co. Route also known as the Butterfield Trail, a transcontinental mail and passenger service between St. Louis and San Francisco that closely followed the Mormon Battalion route through much of the Southwest. All of this and more was documented in an Office of Archaeological Studies report titled *In the Shadow of Standing Mountain: An Archaeological Survey of the Northern Portion of Cookes Range, Luna County, New Mexico*. The comprehensive report of almost 500 pages documented the history of the region and every mining era feature in the survey area.

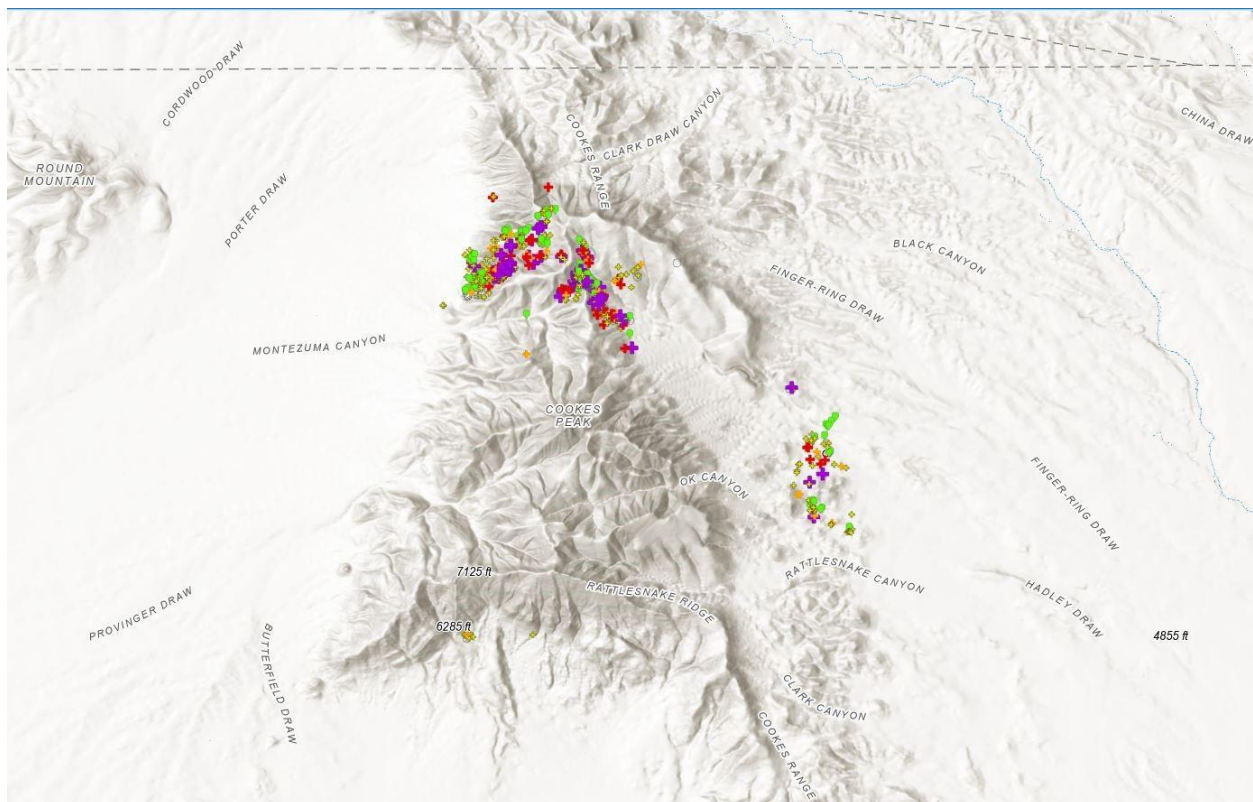

Mine features to the north and east of Cookes Peak

Starting in 2012, the Bureau of Land Management (BLM) made a concerted effort to open the area to more recreational use. Road work was done to bypass locked gates on private property. With more visitation expected, the BLM made safeguarding the abandoned mine features in the area a priority. The BLM expressed their desire to work with the New Mexico Abandoned Mine Land Program to achieve this goal and provided grant funding to help complete an Environmental Assessment and start construction work. This would lead to construction projects addressing almost 300 abandoned mine features starting in 2014 and lasting until 2021.

Innovative use of current technology

A goal of the project was to install vandal-resistant structures that would have a minimal impact on the landscape. In most instances, it was determined that building a structure at the mine entrance would

cause less disturbance to the landscape and provide valuable wildlife habitat. Great care was taken to avoid archaeologically important sites and each feature was checked just before destructive closures took place to make sure that no wildlife remained inside. Bat Conservation International personnel checked each mine feature for active nesting birds and if they were seen, the work at that location was suspended until after nesting season. Weathering steel was used for most of the structures and bars were spaced 5.75" apart to facilitate bat flight. Most horizontal gates and all horizontal gates have at least one removable locking bar in case future entry into the mine is needed.

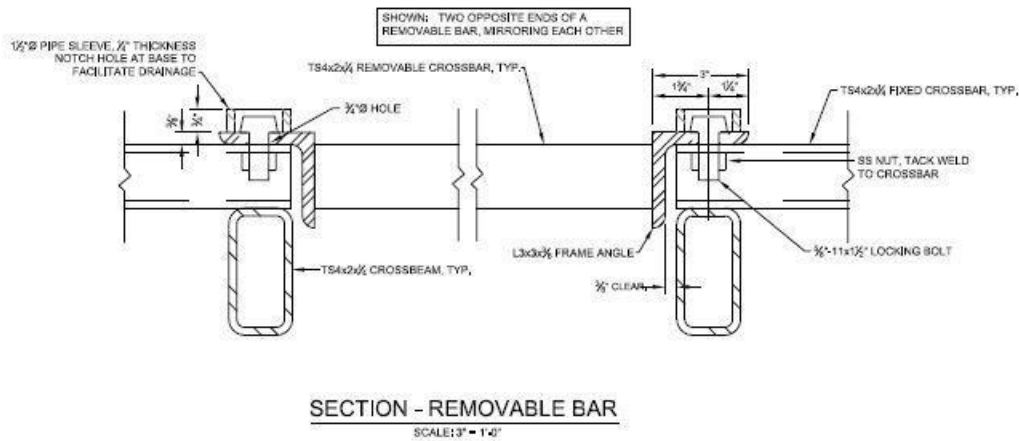

Difficulty of Achieving Reclamation under Existing Conditions

The two biggest challenges for the project were accessing the mine features on very steep and rugged terrain and the inclusion of features within a BLM Wilderness Study Area. The "East" side and "West" side of the project were close in proximity (less than a mile) but had to be accessed from different access routes. Each entailed a one-hour drive from the nearest paved road, much of it over extremely rocky two-tracks paths. (Light green color shows Wilderness Study Areas.)

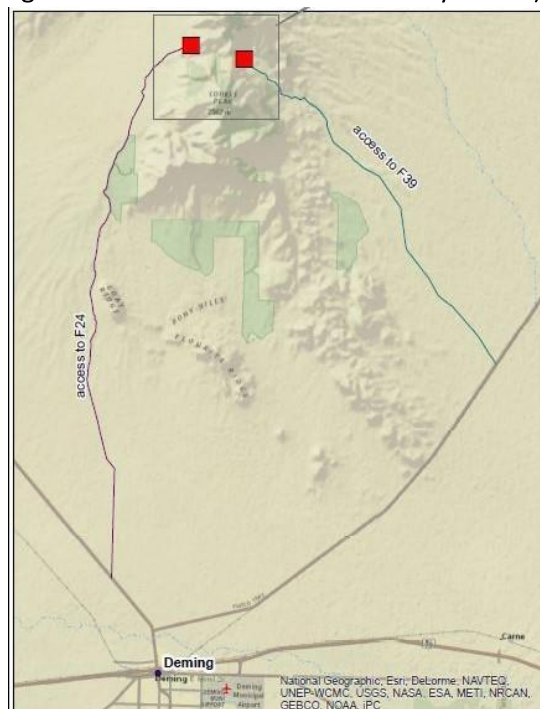

Slopes were lesser on the earlier phases, which allowed for the use of heavy equipment. Archaeological avoidance areas were flagged so that the contractor and project manager knew to avoid them. For the latter phases, the steeper slopes required the use of helicopters and hand-backfilling work. The helicopters would either bring supplies and welding equipment to a cluster of mines or take pre-constructed gates directly to a feature, depending on the contractor's preference. Frequent safety meetings involved all people on the ground and the process was conducted as safely as possible.

The Wilderness Study Area (WSA) was a unique issue for our team. Specific assurances were required in the NEPA process that no motorized equipment would be used within the area and special visual considerations would be utilized outside of the boundary. A helicopter was used to get material and equipment as close to the WSA features as allowable and hand labor took over from there.



Rock rattlesnake (Crotalus lepidus) found during site reconnaissance

On-Site Effectiveness

Consideration was given to each individual mine opening for what the most appropriate closure method should be. Blind adits and shafts with little wildlife habitat potential were treated differently than those with more extensive mine workings. Steel structures were made of weathering steel, which obtains a rust patina and blends in well with the surroundings. Most of the project was adjacent to a BLM Wilderness Study Area and needed to have very little visual impact on the terrain. This meant that any structures should be close to the ground surface as possible. At least 291 dangerous mine openings

were safeguarded through a variety of measures including backfill, horizontal and vertical bat gates, polyurethane foam plugs, steel mesh, steel picket fencing and bat cupolas.

Funding

The U.S. Bureau of Land Management provided grant funding to the New Mexico AML Program to conduct the environmental clearance work and some portions of the construction. The funds were supplemented with OSMRE funding for immediate hazards to public safety. Much planning was done ahead of time to minimize the days helicopters were needed to reach remote locations.

Benefits to the Community

Landowners in the area were very cooperative during construction and supportive of the project overall. Private property located along the access road to Cookes Peak had long kept hikers from getting close enough for a reasonable day hike to the top and back. The BLM wished to provide more access to the mountain range and built a new section of road bypassing the private property. This allowed the public to get much closer to the peak and other wilderness areas while staying on public land. With more visitation expected, the BLM made safeguarding the abandoned mine features in the area a priority. They asked the NMAMLPL to start project development work and provided the funds to do so. Hikers and campers can now get much closer to the peak and explore the entire BLM Wilderness Study Area. Public lands can now be visited safely and the community can enjoy the area's rich, unique mining history.

The various phases of construction work composed one large project that turned out to be a great success. Both the BLM and the NMAMLPL feel this was a good basis for many joint cooperative projects in the future. Funding from the BLM for abandoned mine safeguarding work can arrive somewhat irregularly and the NMAMLPL makes a good partner to conduct environmental clearance work. As a team, we can get a lot done when we identify and supplement our strengths and weaknesses.

2022 NAAMLPL Hard Rock Abandoned Mine Lands Reclamation Awards

NOMINATION PHOTOS

Cookes Peak Mine Safeguard Project
Deming, New Mexico

Award Category:
Physical Safety Hazards

Cookes Peak Bat Study

Contractor	Runyan Construction Inc. of Silver City, NM
Date Completed	November 2014
Cost	\$23,428.94
Work Summary	Two features, both bat closures

Two adits were safeguarded in 2014 with bat gates to facilitate a bat study that biologist Abigail Tobin was conducting at sites in New Mexico and Arizona. A Categorical Exclusion was created for these mine features because the Ms. Tobin's study had time limitations and the full Environmental Assessment was not to be completed until June 2015. Ms. Tobin was awarded a scholarship from the National Association of Abandoned Mine Land Programs in 2015 for her bat research.



Feature 24 receiving two rock bulkheads with bat gates



Finished condition of Feature 24

A culvert with bat gate built at Feature 39



Phase I

Contractor Runyan Construction Inc. of Silver City, NM
Date Completed December 2015
Cost \$59,315.63
Work Summary Four features total, three of them bat closures



Two horizontal gates, held in place with culverts and polyurethane foam, were constructed. Feature 66 is shown here, before and after work took place.



*Feature 272: 120-ft adit with a crosscut to another 10' of drift was used by *Corynorhinus townsendii* and a small species of *Myotis*.*

Finished culvert with bat gate at Feature 272.



BLM Phase A

Contractor	BLM staff
Date Completed	April 2017
Cost	\$200,000
Work Summary	78 features total, 13 structures

The BLM had money available for two employees to construct safeguard measures at abandoned mines in the Las Cruces District. The team concentrated their efforts at the Cookes Peak Project from spring of 2016 to the spring of 2017.



The BLM installing mesh closure at Feature 172094-6





Feature 172095-24: Horizontal Bat Gate being built by the BLM at 100 ft deep shaft.



Perch inside Feature 172095-24 to facilitate owl use



Phase II

Contractor Perikin Enterprises of Albuquerque, NM
Date Completed April 2017
Cost \$322,474.13
Work Summary 64 features total, 40 structures

This was the last phase of work that was able to be completed without utilizing a helicopter.



Typical horizontal bat gate that allows for owl use.



Typical horizontal bat gate that allows for owl use.

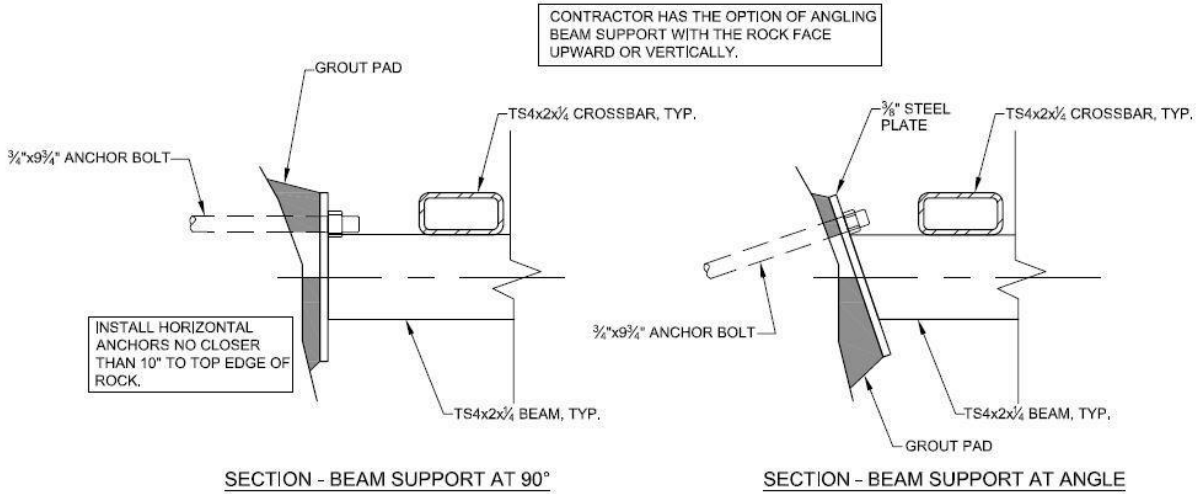

BEAM SUPPORT SIDE SECTION

SCALE: 1/2" = 1'-0"

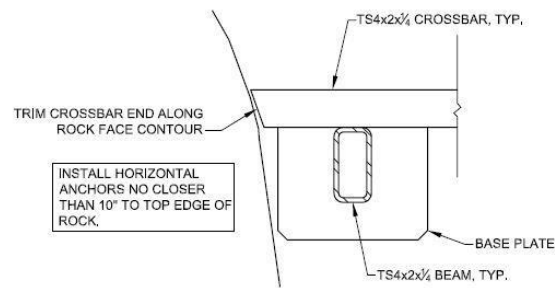
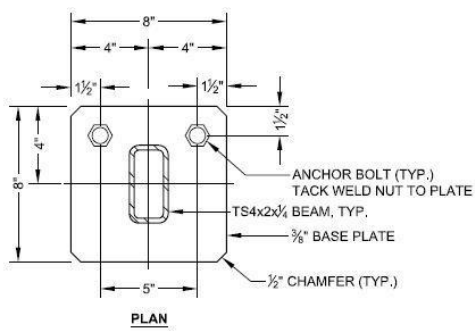

BEAM-CROSSBAR SECTION VIEW

SCALE: 3/4" = 1'-0"

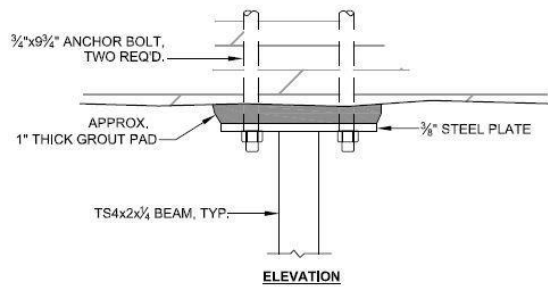

BEAM SUPPORT DETAIL

SCALE: 1/2" = 1'-0"



Horizontal Bat Gate at Feature 281 showing the bars cut to fit the mine opening.

Bat Gate in Rock Bulkhead at Feature 77.



Culvert with Bat Gate installed at Feature 55.



Phase IIIA

Contractor MineGates Environmental, Inc. of Prescott, AZ

Date Completed June 2019

Cost \$216,988.31

Work Summary 39 features total, 18 structures

Helicopter was used to facilitate construction in areas inaccessible with heavy equipment.



Team safety and coordination meeting in the morning before the helicopter work begins.

Bat Gate installed at remote location with the help of a helicopter.



BLM Phase B

Contractor	Hurricane Industries LLC of Joseph, OR
Date Completed	August 2020
Cost	\$154,248.45
Work Summary	45 features total, 40 structures (including three gates, three cupolas and 32 horizontal bat gates)



A helicopter was used by Hurricane Industries to facilitate construction.

Standard horizontal bat gate installed by Hurricane Industries in a Wilderness Study Area.



Another horizontal gate constructed in and around a Wilderness Study Area.



Barn owls observed accessing a constructed bat cupola at 172095-16.



Phase IIIB

Contractor	MineGates Environmental, Inc. of Prescott, AZ
Date Completed	March 2021
Cost	\$481,218.63
Work Summary	59 features total, 38 structures

Helicopter was used to facilitate construction. Hand backfill was done on remote sites.



Gate being delivered by helicopter to remote mine shaft.



Bat Gate constructed by MineGates Environmental in a very remote location.



Backfilled mine shaft in remote location